

## Terms

The definitions of 16 critical terms defined by the 2009 standard<sup>1</sup>

The names and definitions of many GD&T terms have very specific meanings. In some cases they are quite different from general English usage. To be able to function in this language, it is important for each GD&T practitioner to be very familiar with these terms.

### 1. Actual Mating Envelope

The actual mating envelope is a similar, perfect, feature(s) counterpart of smallest size that can be contracted about an external feature(s) or largest size that can be expanded within an internal feature(s) so that it coincides with the surface(s) at the highest points. Two types of actual mating envelopes are described below

- **Unrelated Actual Mating Envelope**

An unrelated actual mating envelope is a similar perfect feature(s) counterpart contracted about an external feature(s) or expanded within an internal feature(s), and not constrained to any datum feature(s).

- **Related Actual Mating Envelope**

A related actual mating envelope is a similar perfect feature(s) counterpart contracted about an external feature(s) or expanded within an internal feature(s) while constrained either by an orientation or location control or both to the applicable datum feature(s).

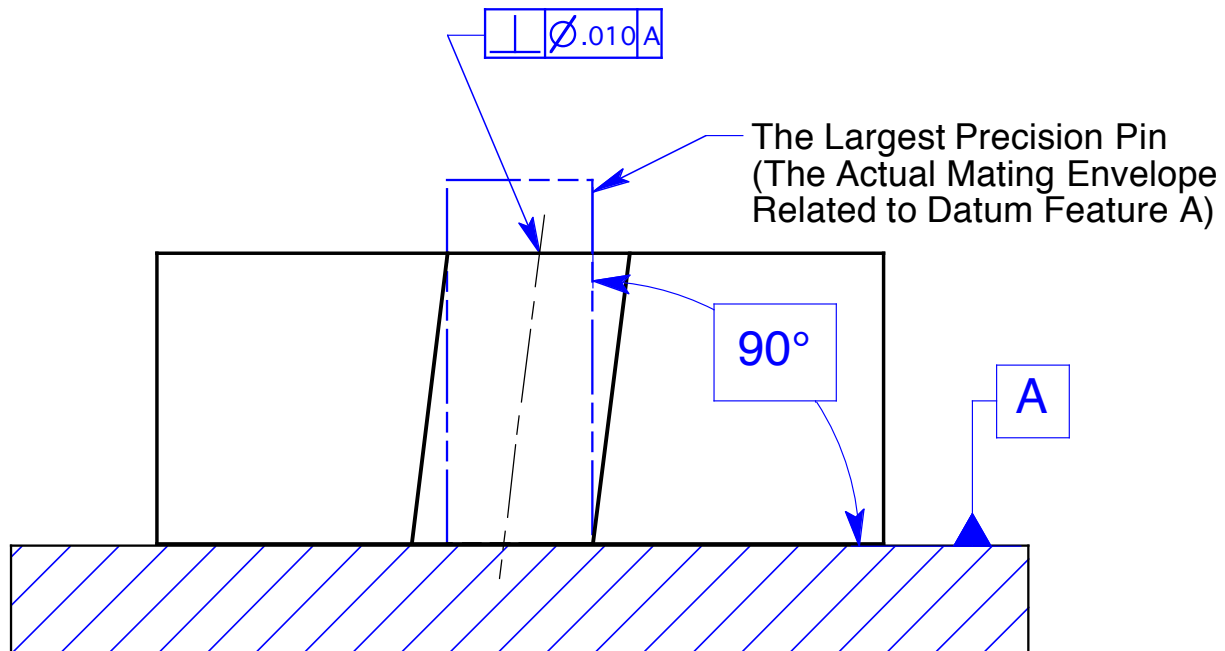

**Figure 3-25 The actual related mating envelope is the largest precision pin, perpendicular to datum plane A that will fit inside the hole.**

## The Actual Mating Envelope

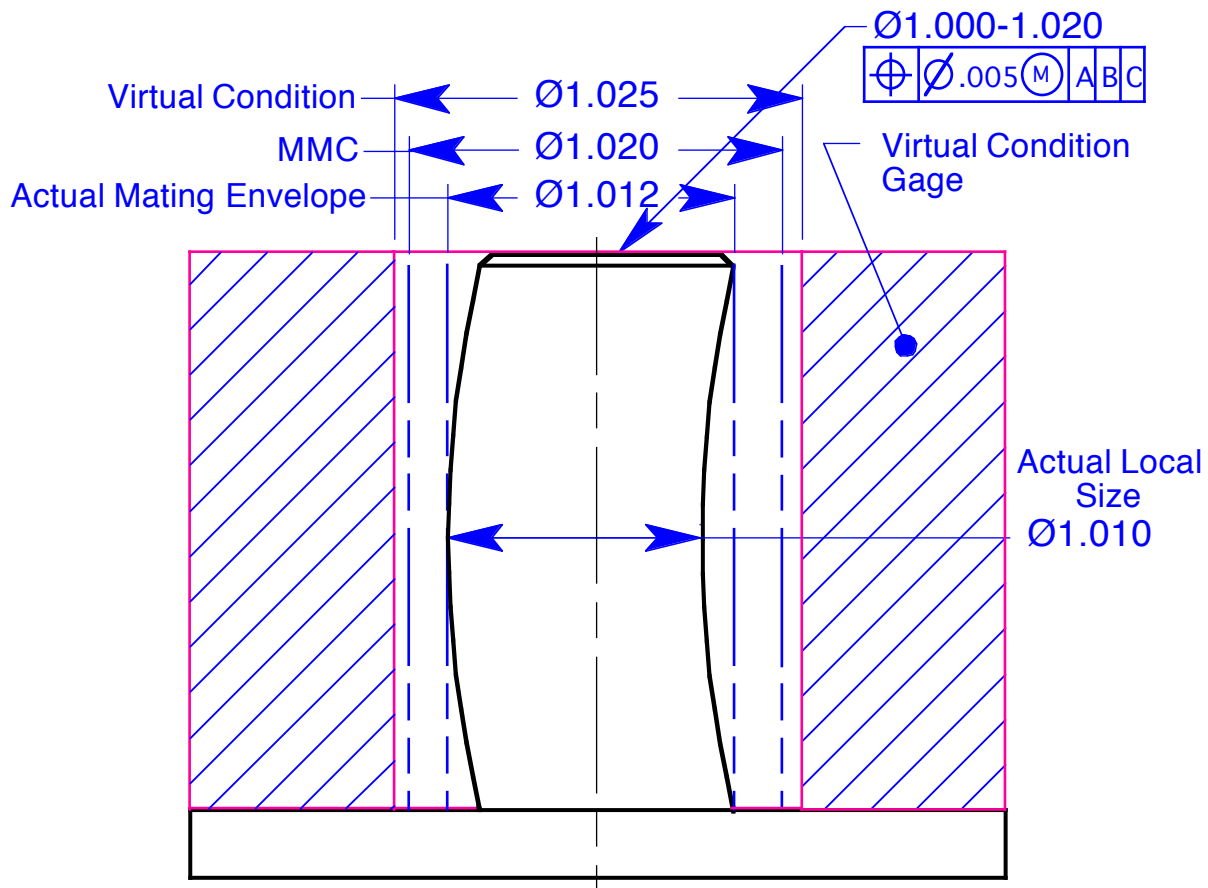

**Figure 7-1 The actual local size, actual mating envelope, maximum material condition, and virtual condition**

### 2. Basic Dimension

A basic dimension is a theoretically exact dimension. Basic dimensions are used to define or position tolerance zones. Title block tolerances do not apply to basic dimensions. The tolerance associated with a basic dimension usually appears in a feature control frame or a note.

### 3. Datum

A datum is a theoretically exact point, axis, line, plane, or combination thereof derived from the theoretical datum feature simulator. A datum is the origin from which the location or geometric characteristics of features of a part are established.

### 4. Datum Feature

A datum feature is a feature that is identified with either a datum feature symbol or a datum target symbol.

<sup>1</sup>Cogorno, Gene R., *Geometric Dimensioning and Tolerancing for Mechanical Design, Second Edition*, McGraw-Hill, New York, 2011, p. 30.

**5. Datum Feature Simulator (Theoretical)**

A datum feature simulator (Theoretical) is the theoretically perfect boundary used to establish a datum from a specified datum feature.

**6. Datum Feature Simulator (Physical)**

A datum feature simulator (Physical) is the physical boundary used to establish a simulated datum from a specified datum feature. Physical datum feature simulators are represented by inspection or manufacturing tooling.

**7. Datum Reference Frame**

A datum reference frame consists of three mutually perpendicular intersecting datum planes.

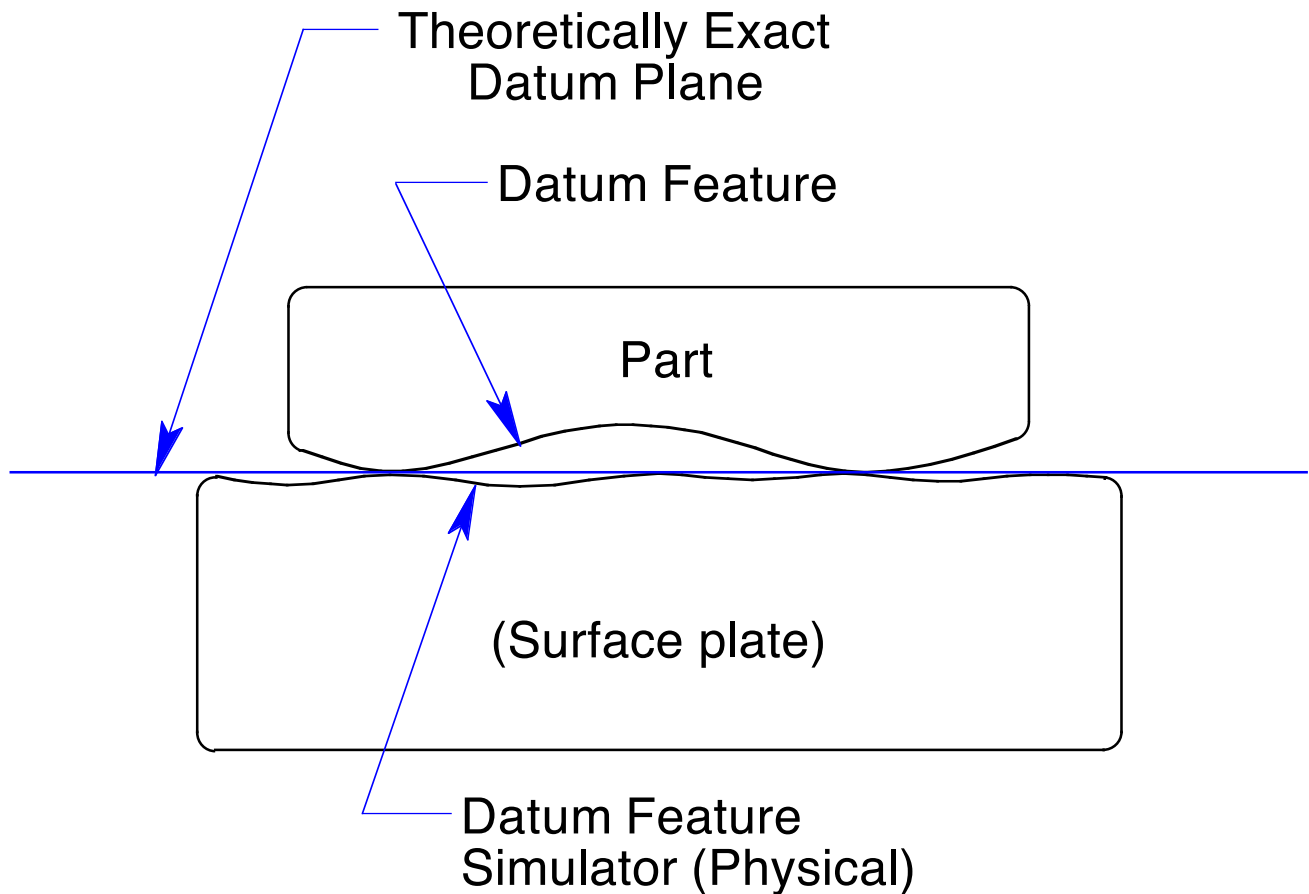

**Figure 3-26 The relationship between a datum, a datum feature, and a physical datum feature simulator.**

## 8. Feature

A feature is a physical portion of a part, such as a surface, pin, hole, tab, slot, or its representation on drawings, models, or digital data files.

## 9. Feature of Size

A feature of size encompasses two types:

- **Regular Feature of Size**

A regular feature of size is a feature, which is associated with a directly toleranced dimension and takes one of the following forms:

- a) A cylindrical surface
- b) A set of two opposed parallel surfaces
- c) A spherical surface
- d) A circular element
- e) A set of two opposed parallel elements

Cylindrical surfaces and two opposed parallel surfaces are the most common regular features of size.

- **Irregular Feature of Size**

The two types of irregular features of size are as follows:

- a) A directly toleranced feature or collection of features that may contain or be contained by an actual mating envelope that is a sphere, cylinder, or pair of parallel planes
- b) A directly toleranced feature or collection of features that may contain or be contained by an actual mating envelope other than a sphere, cylinder, or pair of parallel planes

## 10. Limits of size

- **Maximum Material Condition (MMC)**

The maximum material condition is the condition in which a feature of size contains the maximum amount of material within the stated limits of size. For example, the minimum hole diameter and the maximum shaft diameter.

- **Least Material Condition (LMC)**

The least material condition is the condition in which a feature of size contains the least amount of material within the stated limits of size. For example, the maximum hole diameter and the minimum shaft diameter.

## 11. Material Condition Modifiers

A material condition modifier is specified in a feature control frame, associated with the geometric tolerance of a feature of size or a datum feature of size. The material condition modifiers are shown in the table and figure below.

Material Condition Modifier	Abbreviation	Symbol
Maximum Material Condition (When applied to a tolerance value)	MMC	Ⓜ
Maximum Material Boundary (When applied to a datum reference)	MMB	Ⓜ
Least Material Condition (When applied to a tolerance value)	LMC	Ⓛ
Least Material Boundary (When applied to a datum reference)	LMB	Ⓛ
Regardless of Feature Size (When applied to a tolerance value)	RFS	NONE
Regardless of Material Boundary (When applied to a datum reference)	RMB	NONE

Table 3-1 Material condition modifiers and boundaries, abbreviations, and symbols

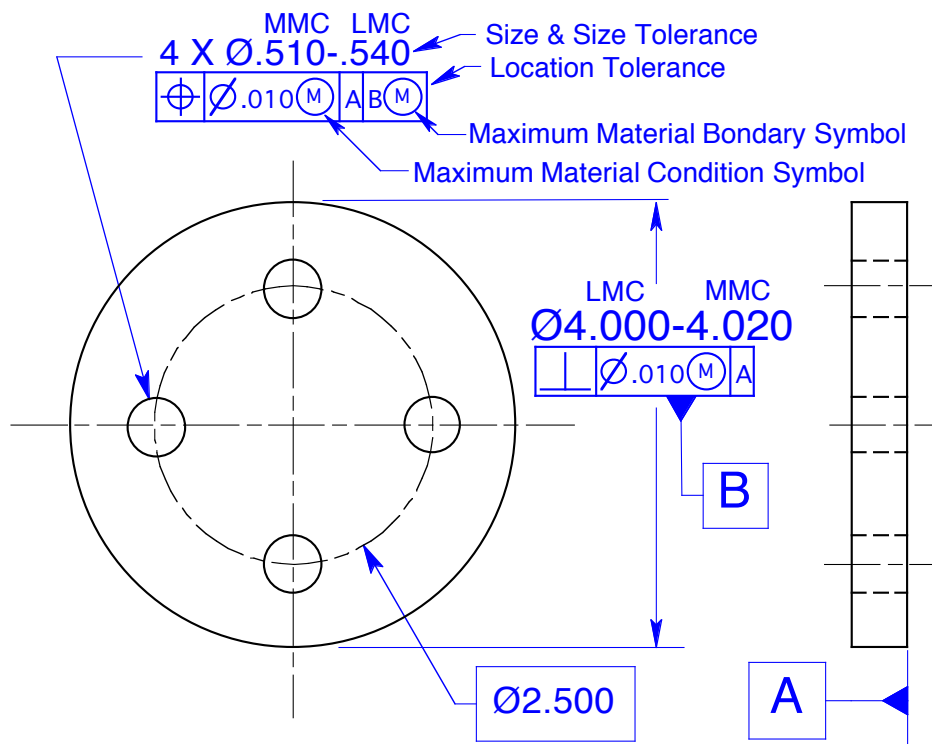

Figure 3-27 Maximum material condition and least material condition limits of size and material condition modifiers

## 12. True Position

True position is the theoretically exact location of a feature of size, as established by basic dimensions. Tolerance zones are located at true position.

## 13. True Profile

True profile is the theoretically exact profile on a drawing defined by basic dimensions or a digital data file. Tolerance zones are located about the true profile.

## 14. Resultant Condition

The resultant condition of a feature of size specified with a MMC modifier is the single worst-case boundary generated by the collective effects of the LMC limit of size, the specified geometric tolerance, and the size tolerance. The size tolerance is the bonus tolerance at LMC. Features specified with a least material condition modifier also have a resultant condition.

Resultant condition calculations for features toleranced at MMC:

### External Features (Pin)

LMC  
*Minus* Geometric Tolerance @ MMC  
*Minus* The Size Tolerance (Bonus)  
Resultant Condition

### Internal Features (Hole)

LMC  
*Plus* Geometric Tolerance @ MMC  
*Plus* The Size Tolerance (Bonus)  
Resultant Condition

## 15. Virtual Condition

The virtual condition of a feature of size specified with a MMC modifier is a constant boundary generated by the collective effects of the considered feature's MMC limit of size and the specified geometric tolerance. Features specified with a least material condition modifier also have a virtual condition.

Virtual condition calculations:

### External Features (Pin)

MMC  
*Plus* Geometric Tolerance @ MMC  
Virtual Condition

### Internal Features (Hole)

MMC  
*Minus* Geometric Tolerance @ MMC  
Virtual Condition

## 16. Worst Case Boundary

The worst-case boundary of a feature is a general term that describes the smallest or largest boundary generated by the collective effects of the MMC or LMC of a feature and any applicable geometric tolerance.

- **Inner boundary specified at MMC**

The worst-case inner boundary is the virtual condition of an internal feature and the resultant condition of an external feature.

- **Outer boundary specified at MMC**

The worst-case outer boundary is the resultant condition of an internal feature and the virtual condition of an external feature.

Features specified with an LMC modifier also have worst-case boundaries.